

# OPERATION MANUAL

## GAP BED LATHE

**Model: BT1640**



# CONTENTS

1、 CONTENTS.....	1
2、 CONSTRUCTION INDICATION.....	2
3、 MAIN APPLICATION AND CHARACTERISTICS.....	3
4、 MAIN TECHNICAL SPECIFICATION.....	3
5、 HOISTING &INSTALLATION.....	4
6、 TRANSMISSION SYSTEM&PARTS.....	7
7、 BEARING DISTRIBUTION AND LIST.....	10
8、 LUBRICATION SYSTEM.....	12
9、 TEST OPERATION AND ADJUSTMENT.....	13
10、 ELECTRICAL SYSTEM.....	18
11、 FRETTE PART.....	21
12、 OPTIONAL ACCESSORY.....	16

## Special attention

- 1、 Removing the wooden crate,if the standard accessories do not accord with the packing list ,please contact the seller.
- 2、 Never attempt to adjust or operate the lathe before reading the operation manual.If malfunction appears send for professional technicians to make maintenance.
- 3、 Check the power whether in accordance with the machine
- 4、 Lubricate all parts requested according to the instruction
- 5、 Check all handles whether well located
- 6、 Wear working cloth, hat, approved safety glass.
- 7、 Forbidden to wear gloves, high-heel shoes and skirts
- 8、 Be subject to alternation without notice during the production procedure
- 9、 Under the condition of normal use and maintenance, if the operation of the machine is not satisfied ,please contact the seller.

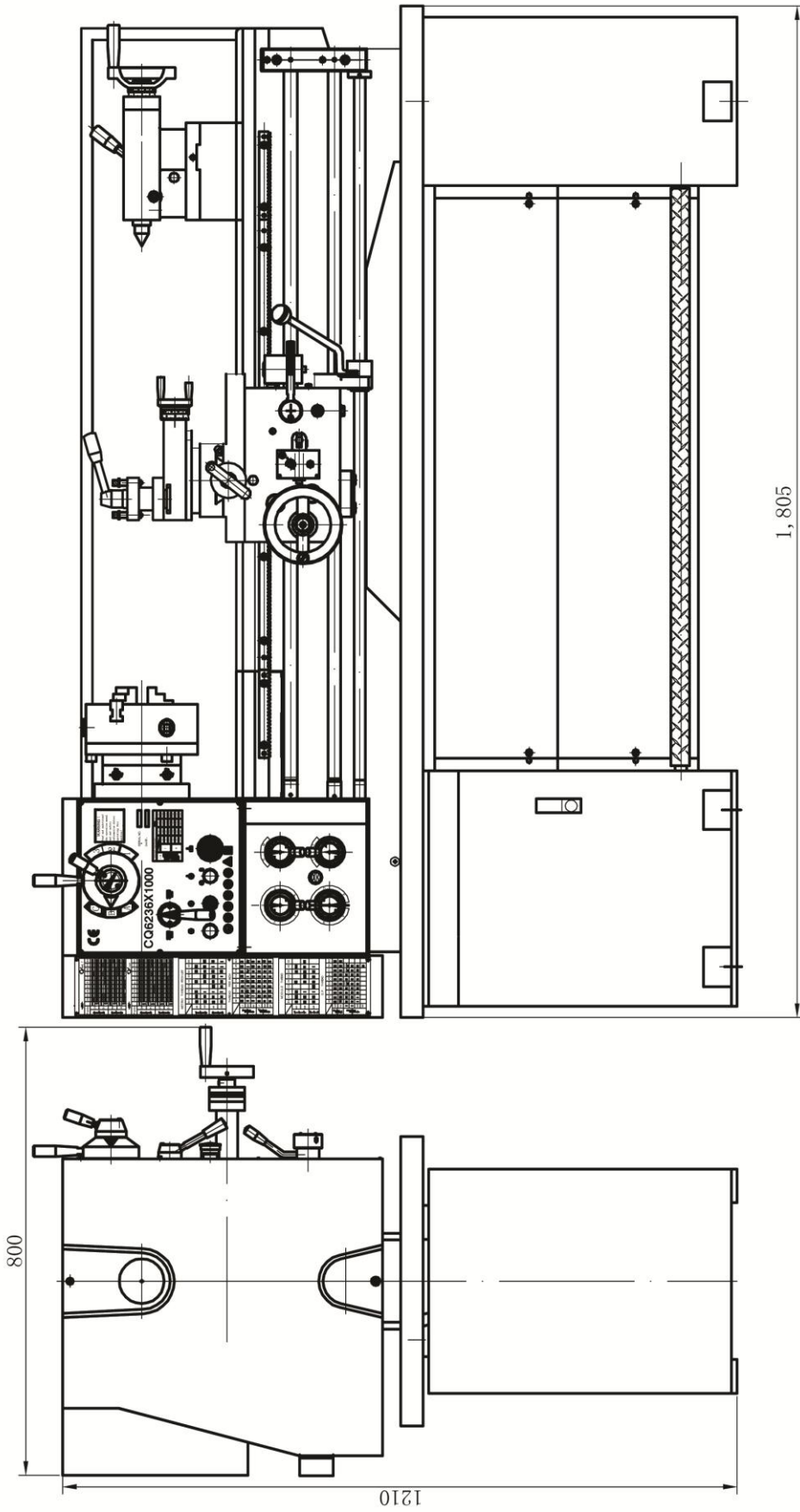

Fig1 Picture for reference

## II PICTURE FOR REFERENCE SEE FIG1

### III THE PRODUCTS' USE AND FEATURE:

The machine is widely used ,not only for turning processing like external circular, hole ,end, taper, cutting slot ,metric thread ,inch thread , module thread , D.P thread ,also for drilling , reaming, set of material, knurling and so on .

The machine with strong rigidity ,suit for powerful and high speed cutting of carbide cutting tools to kinds of black metal and non-ferrous metal.

It is widely used in instrument industry, repair industry, machine manufacturing industry, medium and small production of Metal cutting processing

Right and left handwheel ,metric and inch leadscrew are available for optional.

### IV MAIN TECHNICAL SPECIFICATION

#### 1、 The main performance indexes

##### BT1640

Max swing over bed.....	15 3/4"
Max swing over gap.....	20 3/4"
Max swing over tool post.....	9 1/2"
Distance between centers.....	39 1/2"
Hight center.....	7 3/4"
Width of bed.....	8 1/2"
Cutting tool max. section.....	0.8"x0.8"

#### 2、 Headstock

Spindle bore.....	2"
Spindle taper.....	M.T.NO.6
Spindle nose.....	D5. 1:4(GB5900.3-1997)
Stindle speed rang no.....	9 or 18
Spindle speed rang.....	75-1400r.p.m or 65-1810r.p.m

#### 3、 THREAD &FEED

Guide screw.....	T24 mm×3 mm	
Guide screw of tool post .....	T16 mm×2 mm	
Threads metric pitches.....	0.4—7 mm	(32kinds)
Threads imperial pitches.....	60—4T.P.I	(36kinds)
Modulus thread.....	0.4—3 mm	(22kinds)
Diameter thread.....	44—16D.P	(30kinds)
Longitudinal feeds.....	0.053—1.291 mm	(40kinds)
	0.002—0.051inches	(40kinds)
Cross feeds.....	0.011—0.276 mm	(40kinds)
	0.001—0.011inches	(40kinds)
Guide screw of compound rest.....	T14 mm×2 mm	
Tool post feeding.....	0.02 mm	(0.001inches)

#### 4、 COMPOUND REST AND TOP SLIDE

Max turning Angle of tool post.....	±90°
Top slide travel.....	5 1/4"
Tool post travel.....	9 1/4"

## 5、 Tailstock

Dia. of tailstock sleeve.....	1 1/4”
Morse taper of tailstock sleeve.....	M.T.NO.4
Travel of tailstock sleeve.....	4 3/4”

## 6、 Motor

Power of main motor.....	3HP (50HZ)
Power of coolant pump.....	40w (50HZ)

## 7、 Weight & Measures

Machine size (LxWxH) .....	1900x800x1280mm
Packing size (LxWxH) .....	2000x900x1430mm
Net weight.....	700Kg
Gross weight.....	820Kg

## V HOISTING &INSTALLATION

- 1、 Checking the accessories according to the packing list after removing the wooden crate
- 2、 Sling lathes as shown in the hoisting Fig2 when it is being transported
- 3、 The fixed dimensions of the machine is shown in Fig3. The lathe stand cabinets should be fixed firmly to the base.
- 4、 Remove the protection paper, clean all surfaces off anti-rust oil with mild commercial solvent like kerosene . Then add a layer of thin and even oil, move the parts with hands.
- 5、 Level adjustment: stand cabinets and cement completely solid, then adjust the level. Start with two leveling instrument (with accuracy 0.02/1000), located them on the tool post, the longitudinal and lateral (to each 90 °) two direction . Move the carriage by manual for the whole travel, adjust the mat iron, the gap should be within 2 cases in longitudinal, in cross not more than 3 case. Lock nut , check again , if changes lot , adjust again till reach the request.

## VI TRANSMISSION SYSTEM&PARTS———— Fig4. Table 1 and table renewal.

## VII BEARING DISTRIBUTION AND LIST———— Fig5. Table 2

## VIII LUBRICATION SYSTEM———— Fig6. Table 3

## IX TEST OPERATION AND ADJUSTMENT

### 1 Test:

- 1)、 Read the operation manual before start the machine , know well of the request of the adjustment , operation and lubrication.
- 2)、 Check the tensioner degrees of the belt, finger can press 1-1.5 inch advisable
- 3)、 Handles should be located on low speed first , 20 minutes later , if no problem , improve the speed one by one till the highest speed. Notice: Forbidden to change the speed before the spindle stopped, or damage the machine .

### 2 Handles ----- See Fig9, table 5

#### 1) Spindle speeds choose

Spindle can get 9 or 18 speeds with handles 1, handles 2 and double speed V type v-belts wheel, to reach work different diameter workpiece. See the plate of the spindle speed .

The turning and reversal turning rely on the position of handle 12.

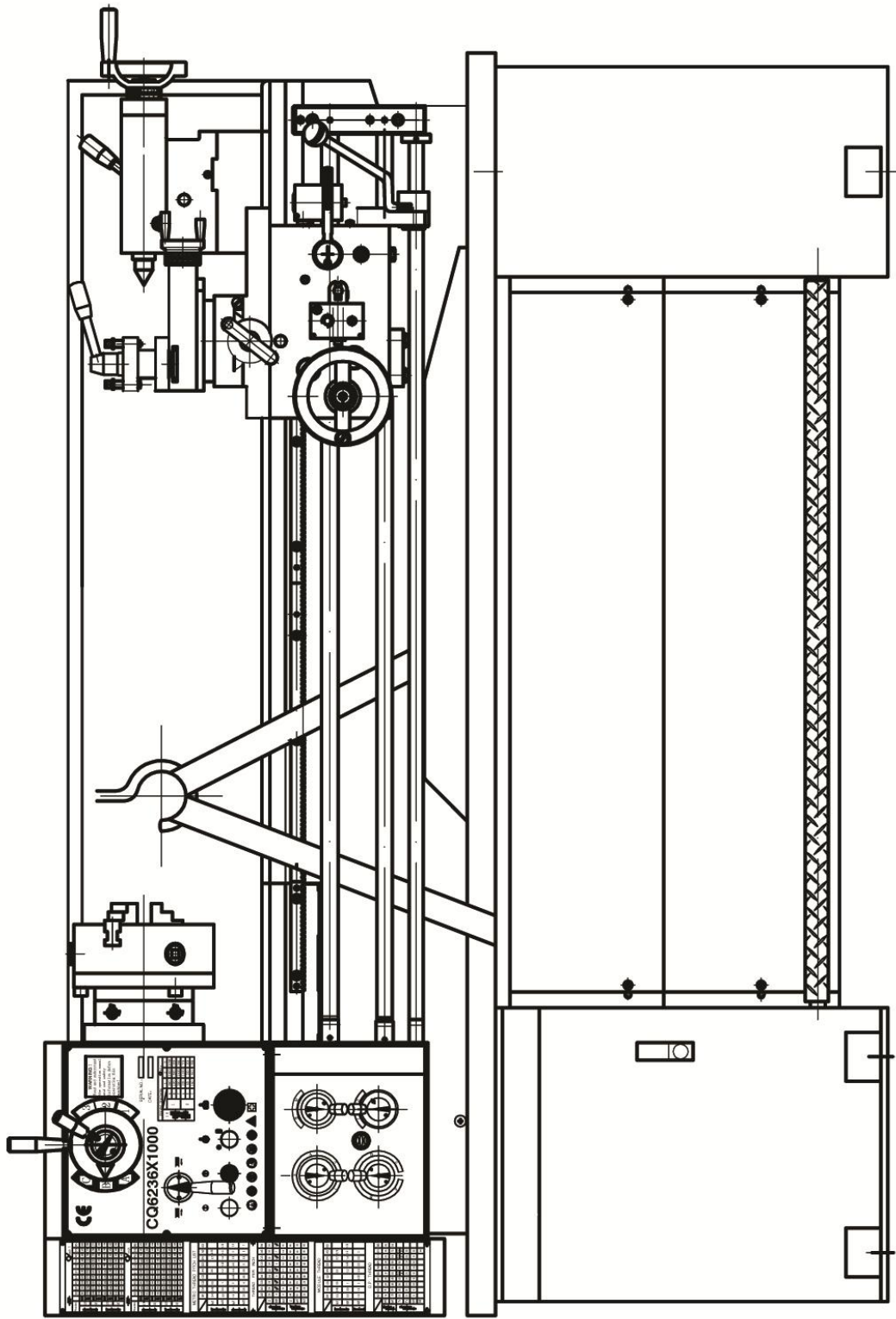

Fig2 Hoisting position

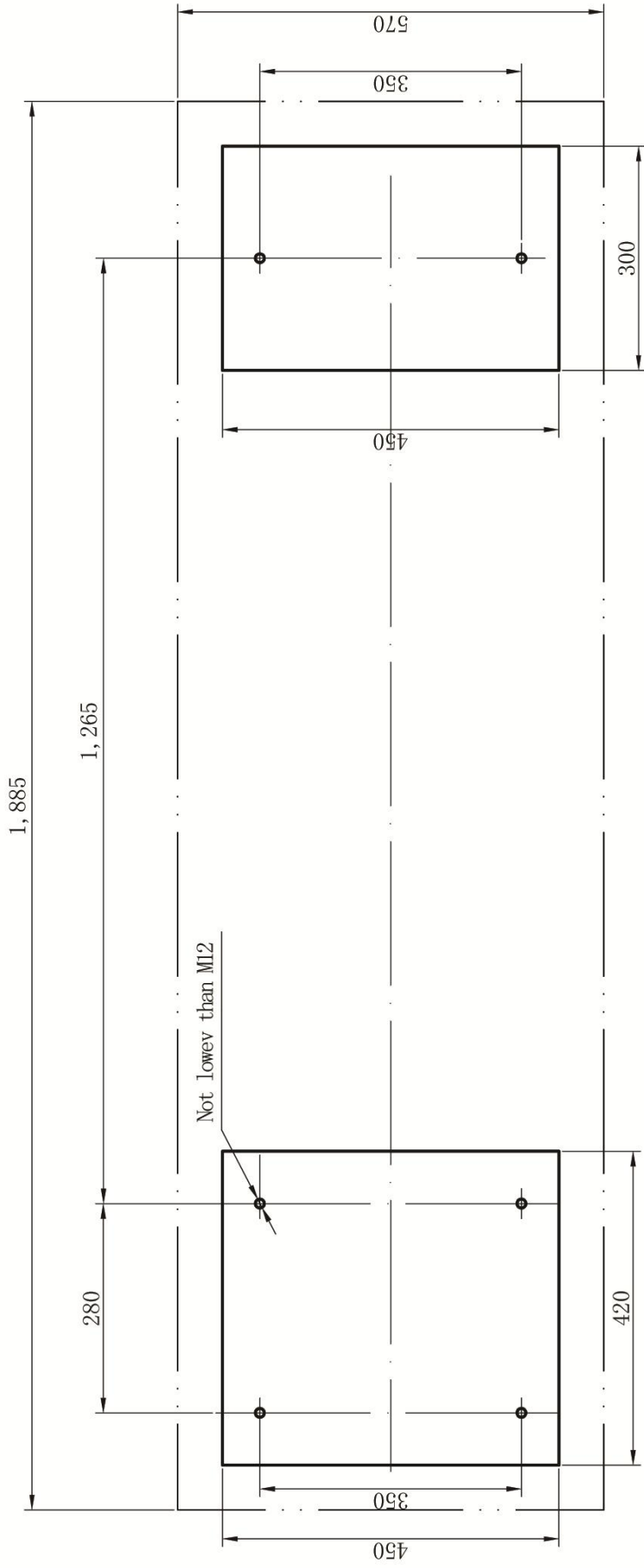

Fig3 Basic screws distribution

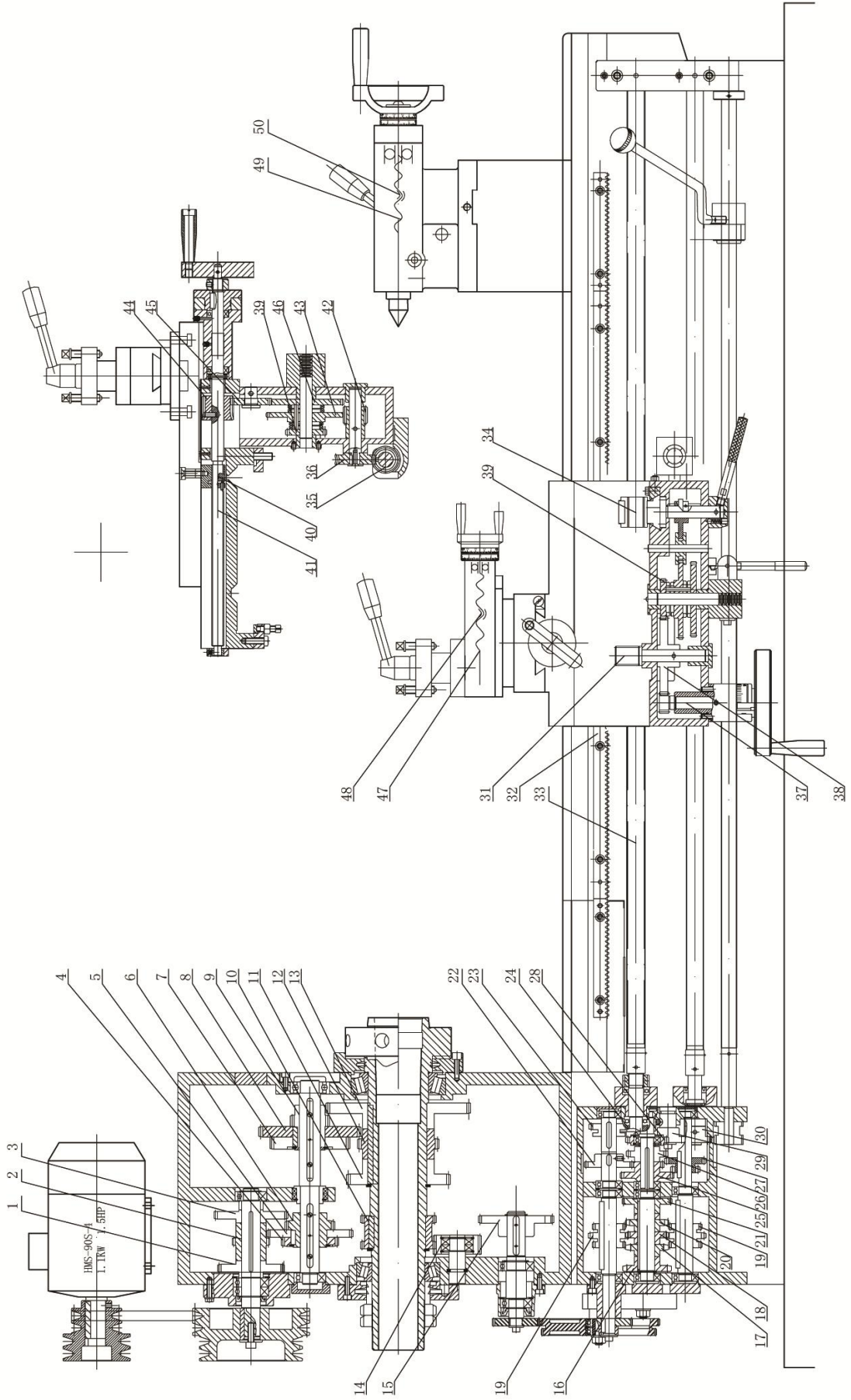

Fig4 Transmission system



## VI. TRANSMISSION SYSTEM & PARTS

TRANSMISSION SYSTEM

SEE FIG4 TABLE 1

TABLE 1

Part	NO	NAME	Teeth no.	Modulus	Pressure Angle	Material	Note
Headstok	1	Gear	42	M2	20°	45	2013
	2	Gear	23	M2	20°	45	2018
	3	Gear	47	M2	20°	45	2019
	4	Gear	36	M2	20°	45	2021
	5	Gear	55	M2	20°	45	2020
	6	Gear	31	M2	20°	45	2022
	7	Gear	45	M2	20°	45	2016
	∞	Gear	58	M2	20°	45	2015
	9	Gear	21	M2	20°	45	2017
	10	Duplicate gear	48	M2	20°	45	2008
	11	Gear	59	M2	20°	45	2029
	12	Gear	46	M2	20°	45	2030
	13	Gear	83	M2	20°	45	2031
	14	Duplicate gear	30	M2	20°	45	2032
	Gear box	15	Gear	48	M2	20°	45
16		Gear	24	M2.25	20°	45	3029B
17		Gear	16	M2.75	20°	45	3031B
18		Gear	18	M2.75	20°	45	3032B
19		triple gear	18	M2.25	20°	45	3005B
				M2.75			
				M2.25			
20		Gear	20	M2.75	20°	45	3003B
21		Gear	28	M2.25	20°	45	3002B
22		Gear	27	M2.25	20°	45	3027C
23		Gear	21	M2.25	20°	45	3025B
24		Gear	21	M2.25	20°	45	3018C
25		Duplicate gear	30	M2.25	20°	45	3026C
			18				
26		Gear	22	M2.25	20°	45	3007C
27		Duplicate gear	15	M2.25	20°	45	3006C
	22						
28	Gear	23	M2.25	20°	45	3009B	
29	Gear	17	M2.25	20°	45	3016C	
30	Gear	15	M2.25	20°	45	3014C	

## VI. TRANSMISSION SYSTEM & PARTS

TRANSMISSION SYSTEM

SEE FIG 4

RENEWAL TABLE

Part	N O.	NAME	Teeth	Modulus	Pressure Angle	Material	Note
Carriage box and saddle	31	Gear	11	M2	20°	45	4028
	32	Rack gear		M2	20°	45	1009, 1010
	33	Guide screw	Single head	3mm or 8T.P.I		45	1005A
	34	Half nut	Single head	3mm or 8T.P.I		ZQSn6-6-3	4003A
	35	Worm	Single head	M2	20°	45	4008
	36	Worm gear	24	M2	20°	ZQSn6-6-3	4017
	37	shaft	12	M2	20°	45	4030
	38	Gear	50	M2	20°	45	4029
	39	Gear	25	M2	20°	45	4014
	40	Guide screw nut	Single head	2mm or 10T.P.I		ZQSn6-6-3	5104A
	41	Guide screw	Single head	2mm or 10T.P.I		45	5103A
	42	Gear	14	M2	20°	45	4019
	43	Gear	51	M2	20°	45	4013
	44	Gear	19	M2	20°	45	5127
	45	Gear	25	M2	20°	45	4010
	46	Gear	48	M2	20°	45	4012
	47	Guide screw	Single head	2mm or 10T.P.I		45	5011A
	48	Screw nut	Single head	2mm or 10T.P.I		ZQSn6-6-3	5012A
Tail stock	49	Guide screw of tailstock	Single head	2mm or 10T.P.I		45	6006A
	50	screw nut of tailstock	Single head	2mm or 10T.P.I		ZQSn6-6-3	6012A
Change gears	1	Gear	21	M1.25	20°	45	3093
	2	Gear	22	M1.25	20°	45	3076C
	3	Gear	24	M1.25	20°	45	2002C
	4	Gear	26	M1.25	20°	45	3075C
	5	Gear	28	M1.25	20°	45	3094
	6	Gear	38	M1.25	20°	45	3090C
	7	Gear	41	M1.25	20°	45	3095
	8	Gear	44	M1.25	20°	45	3077C
	9	Gear	47	M1.25	20°	45	3096
	10	Gear	48	M1.25	20°	45	3039C
	11	Gear	52	M1.25	20°	45	3078C
	12	Duplicate gear	120/127	M1.25	20°	45	3038C

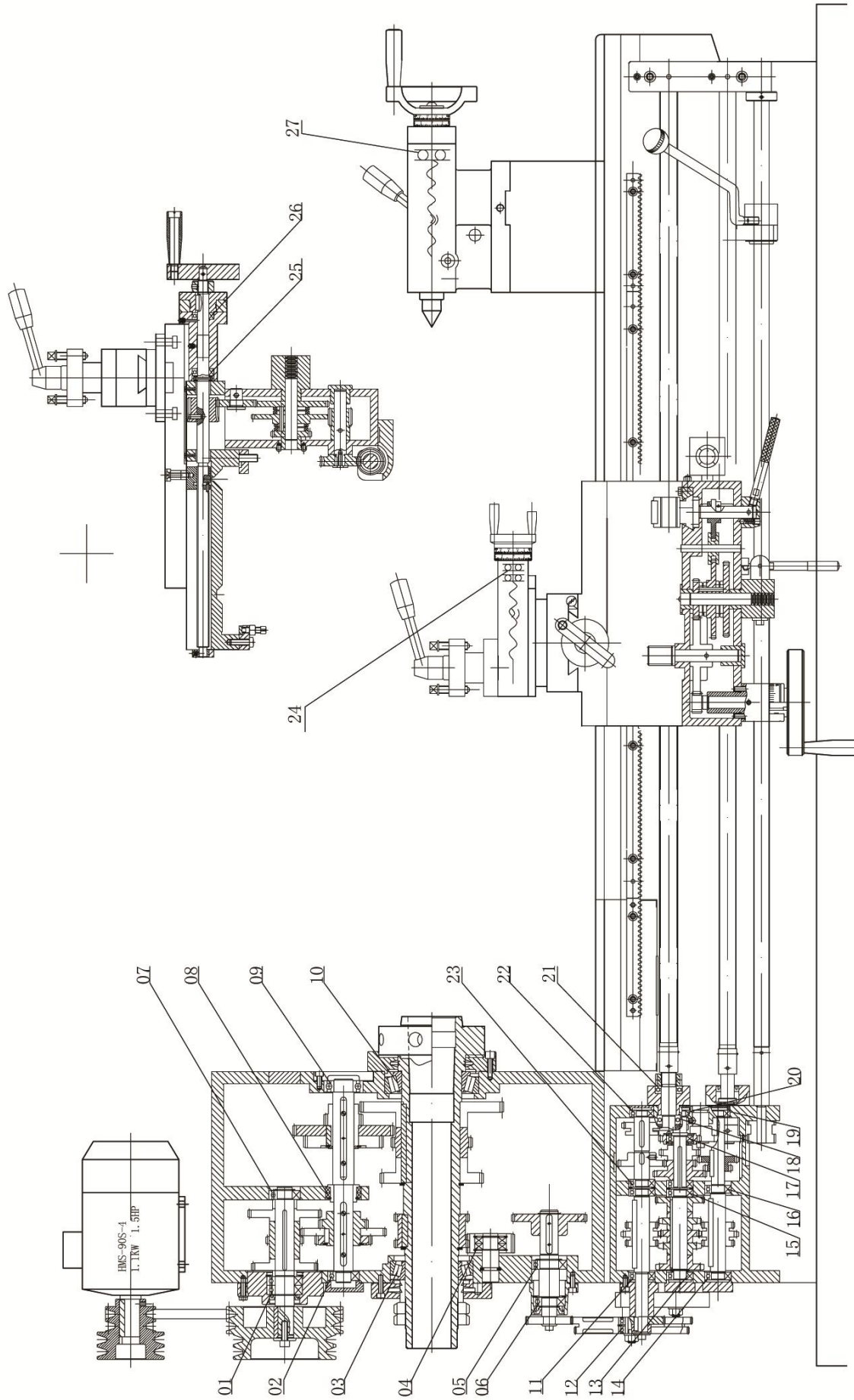

Fig5 Bearing distribution

## VII、 BEARING DISTRIBUTION AND LIST

**BEARING LIST (SEE FIG 5)**

**TABLE 2**

NO.	NAME	Note	Specification	Qty	Parts
01	groove ball bearing	6005	25×47×12	2	headstock
02	groove ball bearing	6004	20×42×12	1	
03	conical roller bearing	32014P5	70×140×25	1	
04	groove ball bearing	16004	20×42×8	2	
05	groove ball bearing	6005	25×47×12	1	
06	groove ball bearing	6004	20×42×12	1	
07	groove ball bearing	6004	20×42×12	1	
08	groove ball bearing	61807	35×47×7	2	
09	groove ball bearing	6205	25×52×15	1	
10	conical roller bearing	32016P5	80×125×29	1	
11	groove ball bearing	6003	17×35×10	1	gear box
12	groove ball bearing	6003Z	17×35×10	2	
13	groove ball bearing	6003	17×35×10	1	
14	groove ball bearing	6003	17×35×11	1	
15	groove ball bearing	6003	17×35×12	2	
16	groove ball bearing	6003	17×35×13	1	
17	groove ball bearing	16003	17×35×8	1	
18	thrust ball bearing	51103	17×30×9	1	
19	groove ball bearing	6002	15×32×9	1	
20	groove ball bearing	6002	15×32×10	1	
21	thrust ball bearing	51104	20×35×10	1	
22	groove ball bearing	6002	15×32×9	1	
23	groove ball bearing	6003	17×35×11	1	
24	thrust ball bearing	51101	12×26×9	2	
25	thrust ball bearing	51102	15×28×9	1	
26	thrust ball bearing	51102	15×28×10	1	
27	thrust ball bearing	51101	12×26×9	1	tailstock

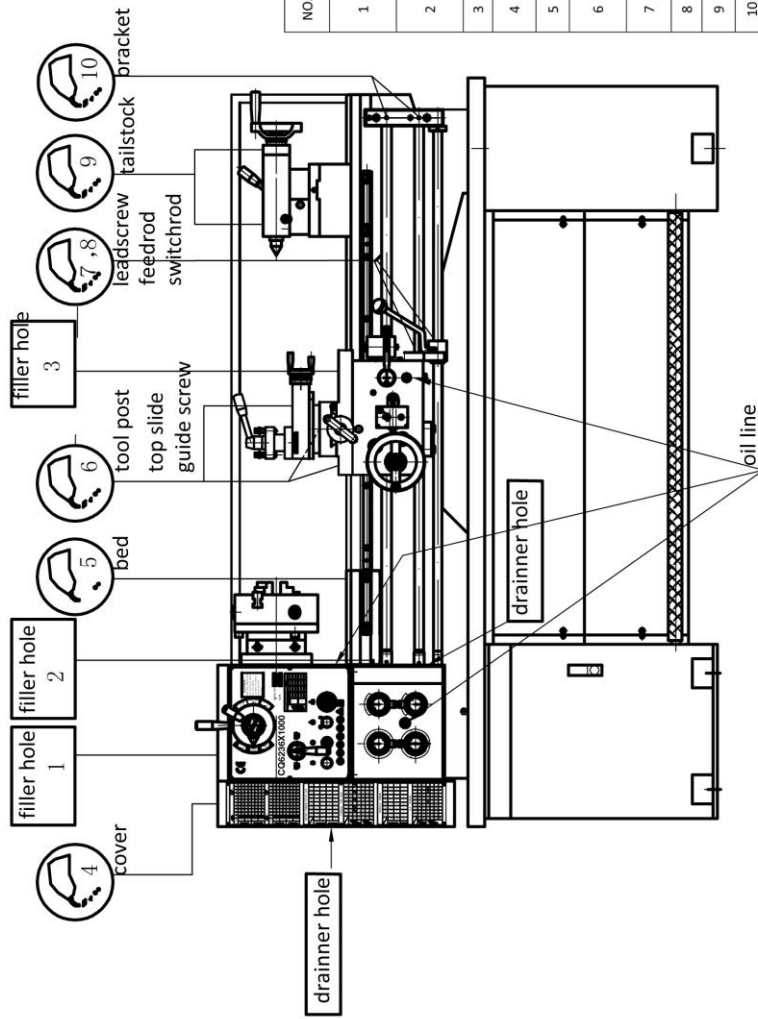

Table 3

NO.	LOCATION	HOW	HOW MUCH	HOW LONG TO FILL UP	OIL QUALITY
1	HEADSTOCK	Remove the screws of filler on left side up	L	Once first month, then every two month	NO.15 SY1229
2	GEAR BOX	Open top cover remove the screws of filler	L	Once a month	NO.22 L-AN GB443-1989
3	SADDLE	open oil plug	L	Once a day	NO.22 L-AN
4	CHANGE GEAR	open the cover	Approp	Once a day	NO.22 L-AN
5	BEDWAYS	By oil gun	Approp	Twice a day	NO.22 L-AN
6	TOOL POST/ TOP SLIDE/ GUIDE SCREW	By oil gun	Approp	Twice a day	NO.22 L-AN
7	LEADSCREW, FEED ROD, SWITCH ROD	By oil gun	Approp	Once a day	NO.22 L-AN
8	HALF NUT	By oil gun	Approp	Once a day	NO.22 L-AN
9	TAILSTOCK	By oil gun	Approp	Once a day	NO.22 L-AN
10	BRACKET	open oil plug	L	Twice a day	NO.22 L-AN

Fig 6 Lubrication

**2) Feed and pitch** The main way to maintain different feeding and pitch by gear box and change gears. According to the gears chart,different gears and movement of handle from 04-07 ,we can obtain 40 feeding,more than 30 metric and inch pitch,20 module and pitch

INDICATOR			TABLE		
T	mm	SCALE	T	mm	SCALE
0	0.5	///	15	0.45	1
	0.6	///		0.9	1
	0.75	///		1.25	1
	1	///		1.8	1
	1.5	///		2.25	1
	3	///		2.50	1
16	0.4	1-8	14	4.50	1
	0.8	1-3-5-7		5	1
	1.2	1-8		0.7	1-5
	1.6	1-5		1.4	1-5
	2	1-8		1.75	1-5
	2.4	1-3-5-7		2.8	1
	3.2	1		3.5	1-5
	4	1-3-5-7		7	1-5
	4.8	1-5			
	6	1-8			

Fig7 thread indicator

position same.If not an integer,teeth wrong . We can change the movement direction or thread chasing dial .See left Fig 7.Meaning checking Table 4.

Table 4

code	significance
1—8	Any a scribed line alignment, press half nut ,teeth right
1	scribed line 1 alignment, press half nut ,teeth right
1.5	scribed line 1 or 5 alignment, press half nut ,teeth right
1.3. 5.7	scribed line 1 or 3or 5 or 7 alignment, press half nut ,teeth right
	No need of thread indicator ,press half nut anywhere,teeth right

**3 Adjustment**

1)adjustment of clearance of the spindle see fig8( Turn below page16 )

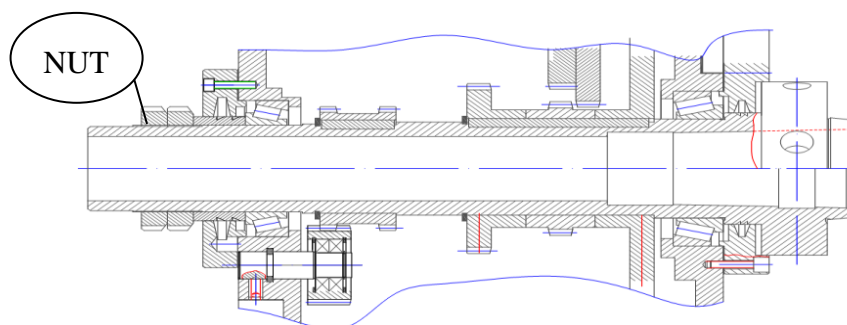

**.Notice:When change the position of the handles,spindle must stopped first .**

**3)Saddle compound rest**

Turn handwheel 08 ,make the saddle move left or right. Turn handwheel 08,make the tool post move forward or backward. Loosen nut 20 ,change the rotation Angle of top slide. Tighten nut 20, Turn handwheel 18,move the top slide to achieve the requirements of taper processing

Change the position of the handwheel 9 can obtain auto feeding .

UP-Saddle longitudinal move

DOWN-Tool post horizontal move

MIDDLE-Stop thread by manual with half nut

**4) Thread indicator 11**

When screw turn one circle,the work piece rotation is an integer ,teeth

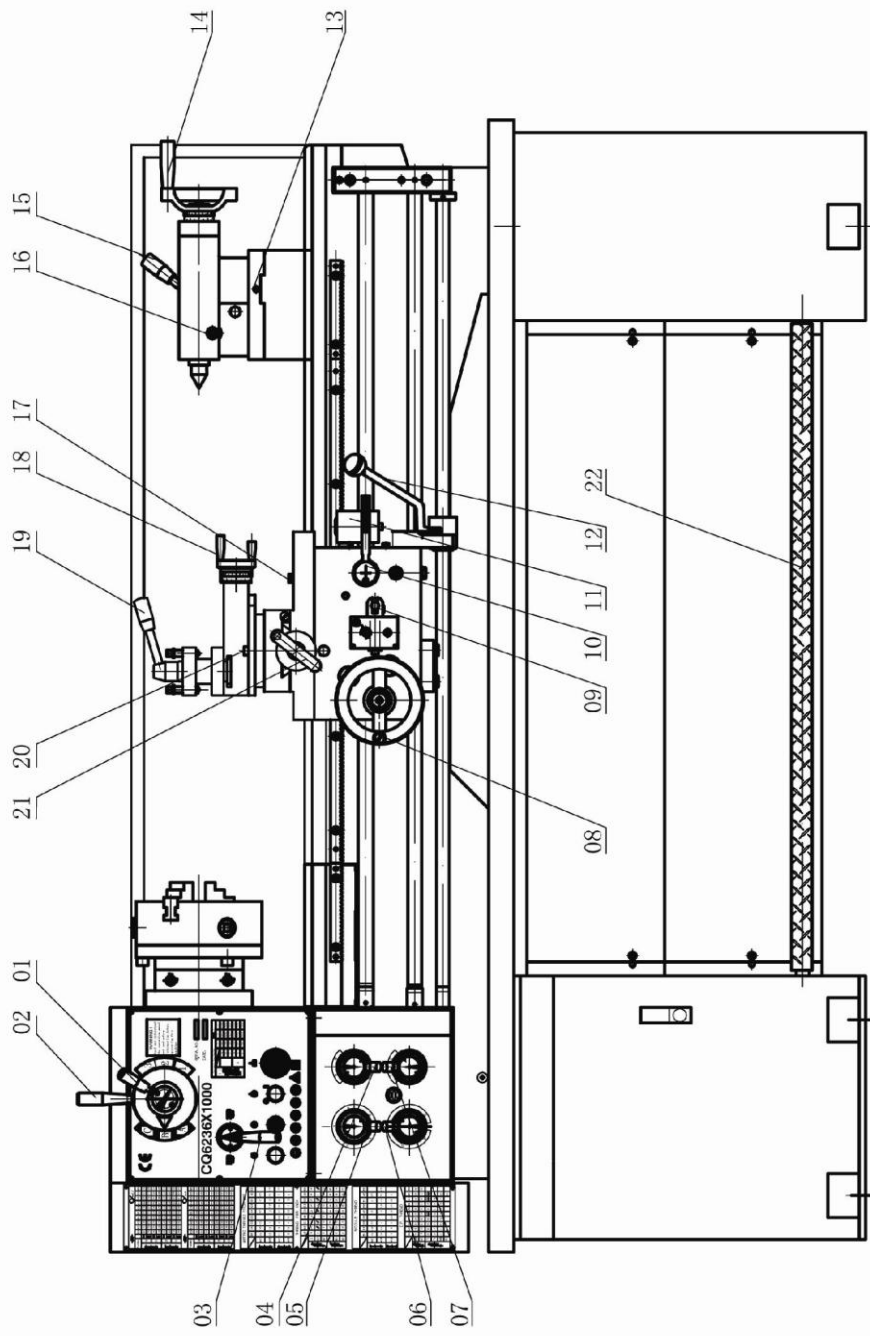

Fig 7 Handles

## Handles and use

Table 5

NO.	INSTALLATION	NAME	FUNCTION
01	headstock	variable speed handle I	spindle speed
02		variable speed handle II	spindle speed
03		turn &reverse hands	change the move direction of the saddle
04	feed box	thread or feed handle	S-feeding M-threading
05		feeding and pitch handle	obtain appropriate feeding or pitch
06		feeding and pitch handle	
07		increases times optional handle	
08	carriage	carriage movement handle	carriage move left or right
09		vertical and horizontal handles	control move direction or manual
10		handle of half nut	the combination or separation of the thread
11		thread chasing dial	the combination or separation of thread dial
12		start switch handle	turn or reverse turn or stop of the machine
13	tailstock	adjust screw of tailstock center	the coaxial tolerance of tailstock and spindle
14		handwheel of tailstock sleeve	move forward or backward of the tailstock sleeve
15		lock handle of the tailstock	tailstock movement
16		lock handle of the tailstock sleeve	tailstock sleeve clearance and movement
17	compound rest and saddle	lock nut of bed	lock the saddle
18		handwheel of top slide	make the top slide move forward or backward
19		lock nut of tool	control of the rotation of the tool
20		Lock nut of rotary tool	control of the rotation of the rotary tool
21		tool post handwheel	tool post move forward or backward
22	bed	foot brake switch	control the rotation of the lathe



Spindle adopt high precision conical roller bearing, after period of time, bearing trace to wear, the gap increases,so adjustment is needed ,please follow below steps:Loosen the two nut at spindle back-end,tighten front nut,test the spindle by hand with micro tight, backward 1/4 circle,then tighten one back nut .

2) clearance adjustment between tool post and top slide: Turn the screw at the right hand to right side ,the gap becomes small,otherwise becomes big.

3) gap adjustment of guidescrew nut:see fig10,Turn screw 1 to eliminate the gap ,the gap can't be too small or wear is intensified.

4)mount or detach of chuck and face plate:see fig11,the spindle connect the chuck by D-Cam and pull pins.When mounting,put the three pull pins of the chuck into the three wholes on the spindle face end,then turn the three cams with the aid of square headwrench,when turning the cams clockwise,the chuck will be locked,when turning the cams counter-clockwise to certain point,the chuckcan be detached.

#### † Electrical system

1) 380V -400V 50HZ,60HZ Electrical dirgram see Fig 12 form8 Electrical components

2) 110V -220V 50HZ Electrical dirgram see Fig 13 form9 Electrical components

Check the power and frequency whether in accordance with the request of the machine ,add 25 A fuse.

Switch rod 12 located in the middle position,the machine stop,to make sure the machine unable to start ,KA with electricity,then next step continue.

Switch rod 12 move upwards,the spindle turn counterclockwise,move it down,the spindle turn clockwise.If not , cut off power supply, exchange of any two power into line

3) Lathe must have a good grounding lines.

4) The circuit diagram is only for reference. Practical circuit diagram covered at the back of the electrical box to facilitate the maintenance

#### † TROUBLE SHOOTING PART form 6

No.	Name	Maerial	Qty	Specification	Note
1	Horizontal feeding nut	ZQSn6-6-3	1	CQ6236-5104	Fig14
2	Half nut	ZQSn6-6-3	1	CQ6236-4003	Fig15

#### † OPTIONAL ACCESSORIES see Form9 form7

No.	Name	Qty	Note
1	steady rest	1SET	
2	follow rest	1SET	
3	4 jaw chuck	1SET	
4	face palte	1SET	
5	coolant system	1SET	
6	chuck cover	1SET	Switch power
7	live center	M.T.NO.3	1SET
p8	footbrake system	1SET	

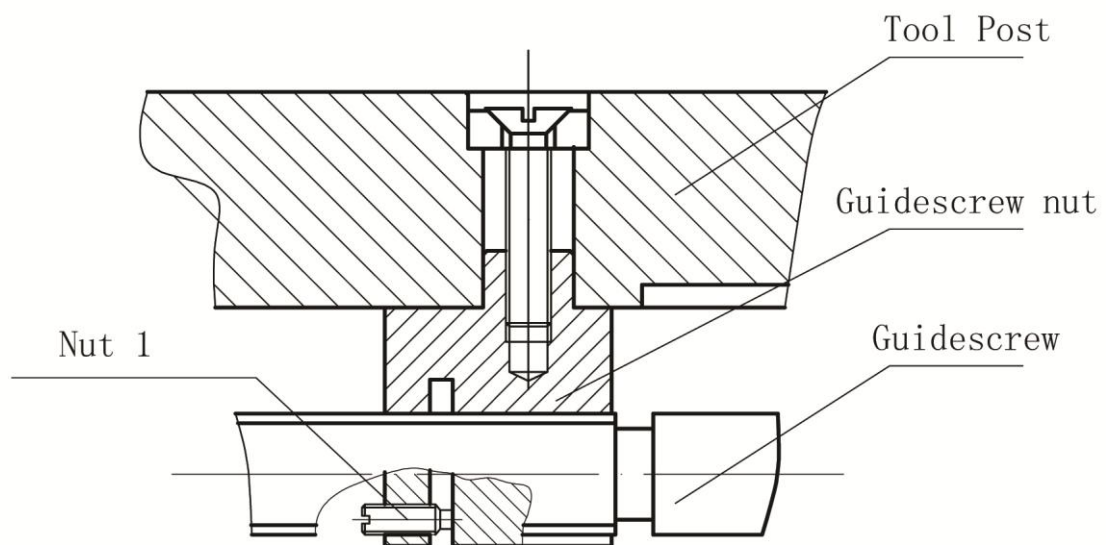

Fig 10 Adjust the gap of horizontal feeding nut

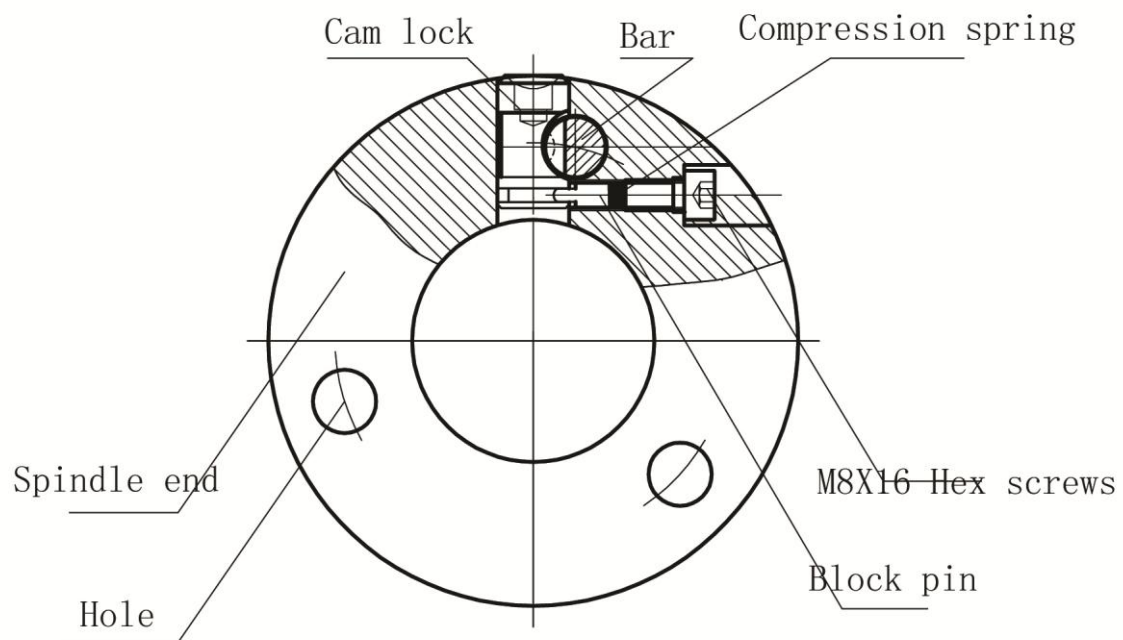

Fig 11 chuck or face plate lock structure

**Electrical components list****Table 8**

NO.	CODE	NAME	MODEL	QTY
1	M1	main motor	Y90S-4 380V	1
2	M2	cooling motor	DB-12	1
3	KM1 KM2	contactor	LC1-D1209 24V	2
4	KM3	cooling relay	LC1-D1209 24V	1
5	KA	middle relay	32C4-40 24V	1
6	QM	circuit breaker	DZ47-63,3P	1
7	QF	circuit breaker	DZ47-63,1P	1
8	TC	transformer	JBK5-63	1
9	EL	work light	JBK9-2A orJL50D-1	1
10	HL	indicator	AD118.8/21-8GZ	1
11	SB <sub>1</sub>	emergency stop button	LA38 lth 10A	1
12	SB <sub>2</sub>	point start button	L38-11/207	1
13	1SA,2SA	positive &negative switching	LXW5-11D1	2
14	3SA	switch power of cover	LXW5-M/L	1
15	4SA	switch power of chuck cover	LXW5-M/L	1
16	5SA	cooling control switch	LAY-11X/2	1
17	SF	power switch of footbrake	LXW5-11N1/L	1

**Electrical components list(Single phase) Table9**

1	M1	main motor	Y90L2-4 220V 1.5KW	1
2	FR	thermal relay	T16	1
3	FU	fuse	RT23-16 24V 2A	1
4	SB1	button	LA38 ITH 10A	1
5	SB2	button	LA38-11/207	1
6	SQ1	micro switch	LXW5-11D1	1
7	SQ2	micro switch	LXW5-11D1	1
8	HL	indicator	AD118.8/21-8GZ	1
9	T	control transformer	JBK5-63	1
10	KA	middle relay	32C4-40 24V	1
11	KM1	Ac contactor	LC1-D1209 24V	1
12	KM2	Ac contactor	LC1-D1209 24V	1

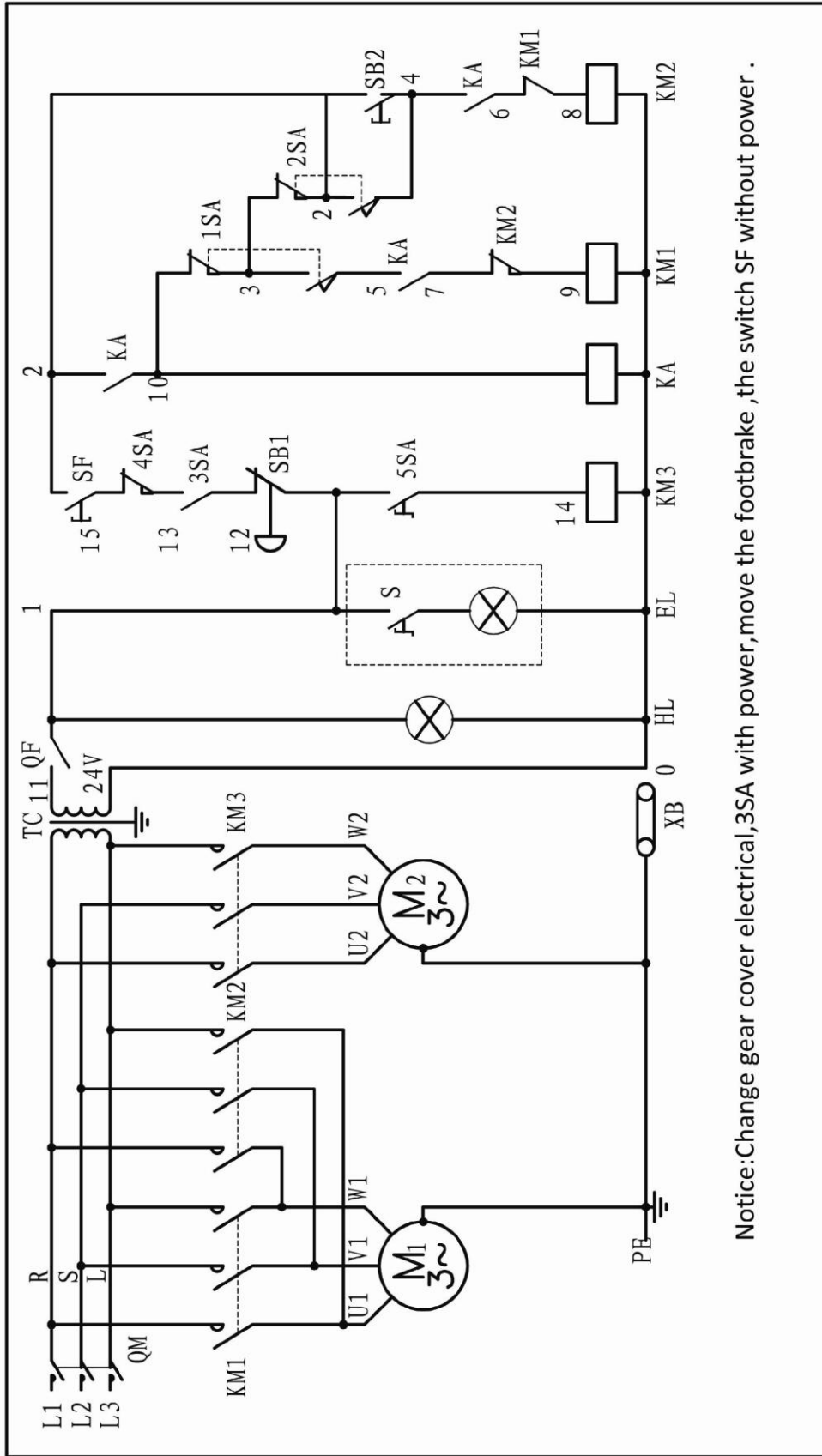

Notice: Change gear cover electrical, 3SA with power, move the footbrake, the switch SF without power.

Fig12 380V-440V 50hz, 60hz wire diagram

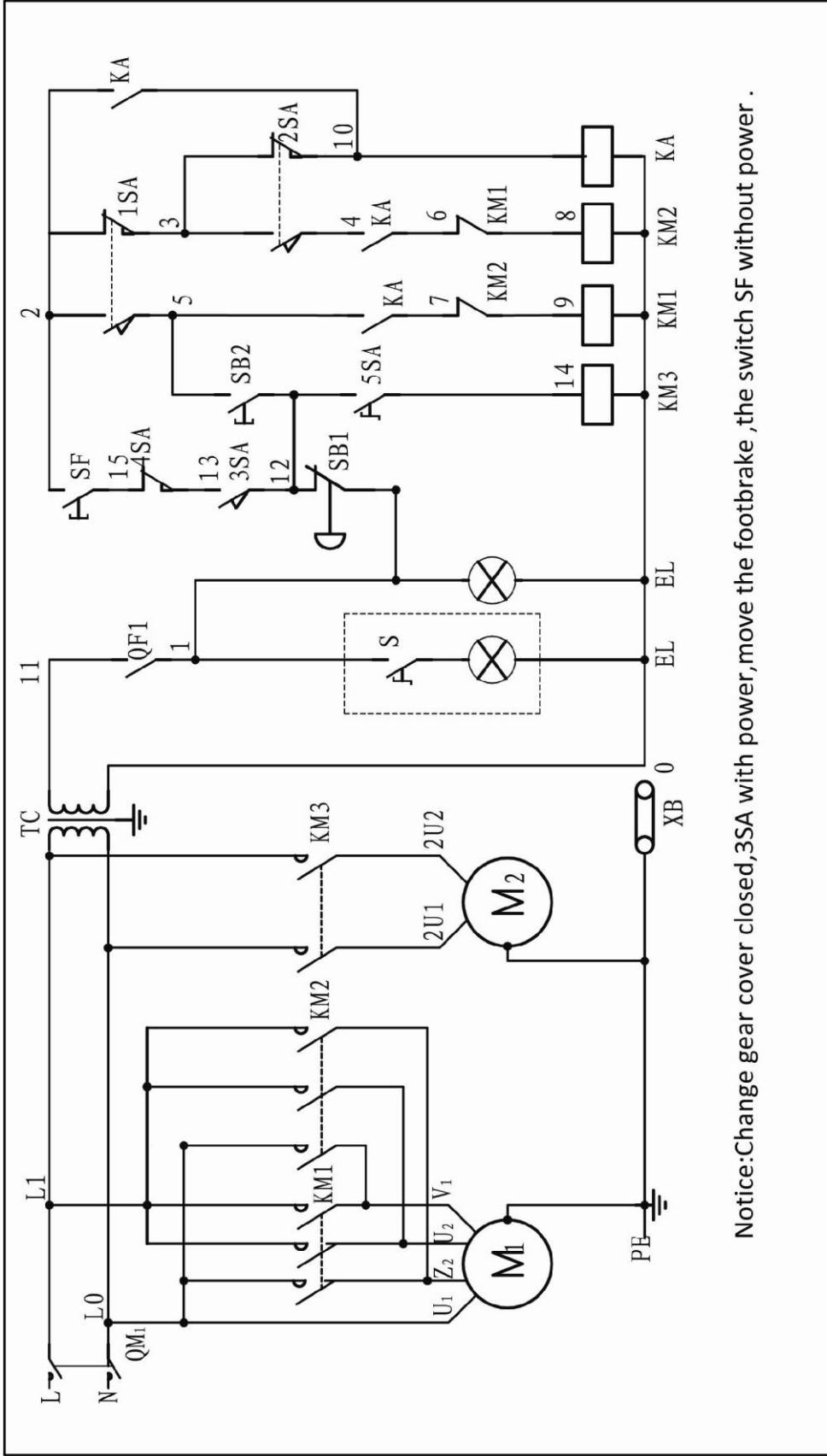

Notice: Change gear cover closed, 3SA with power, move the footbrake, the switch SF without power.

Fig13 110V-220V 50hz electrical diagram (single phase)

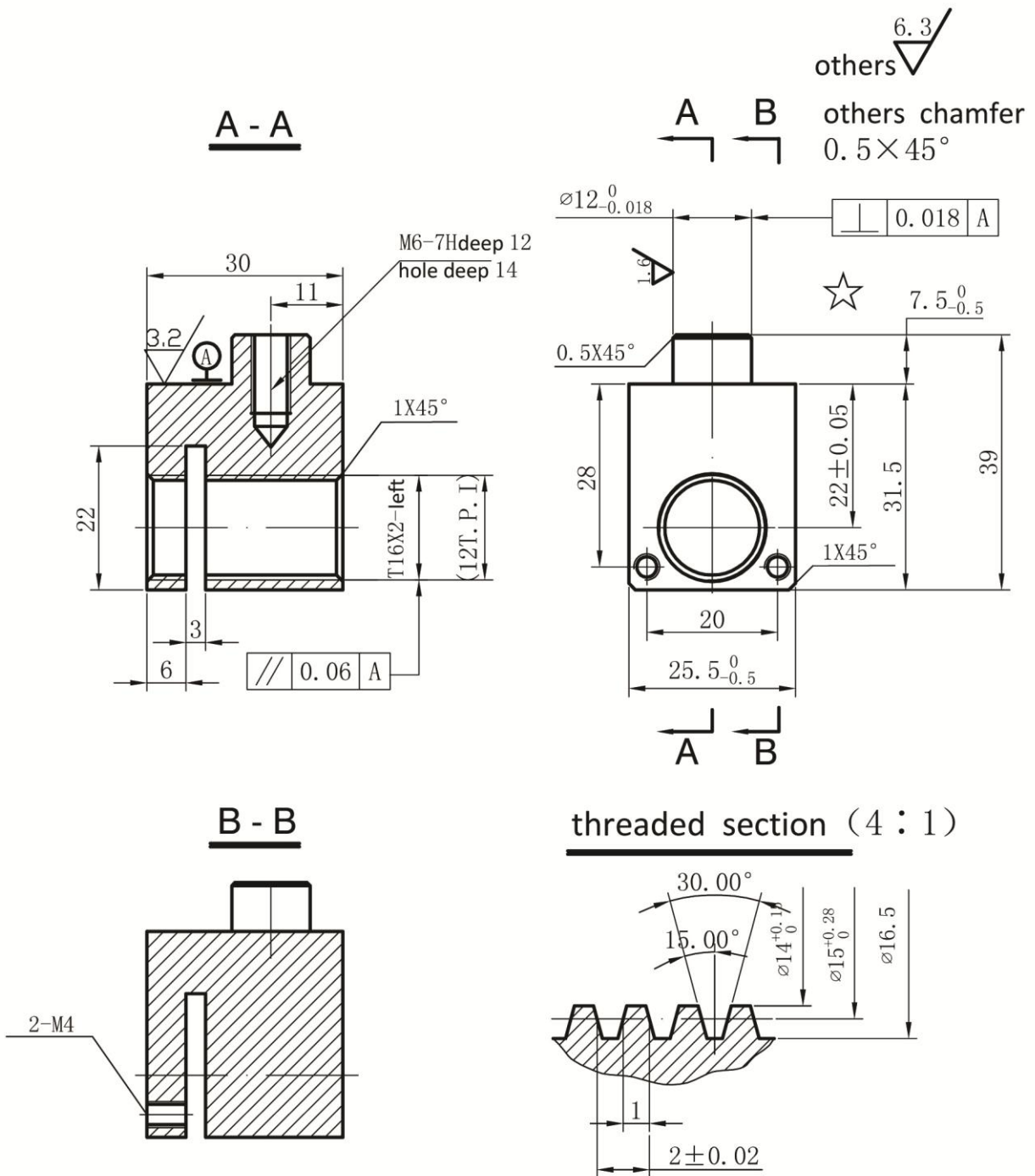
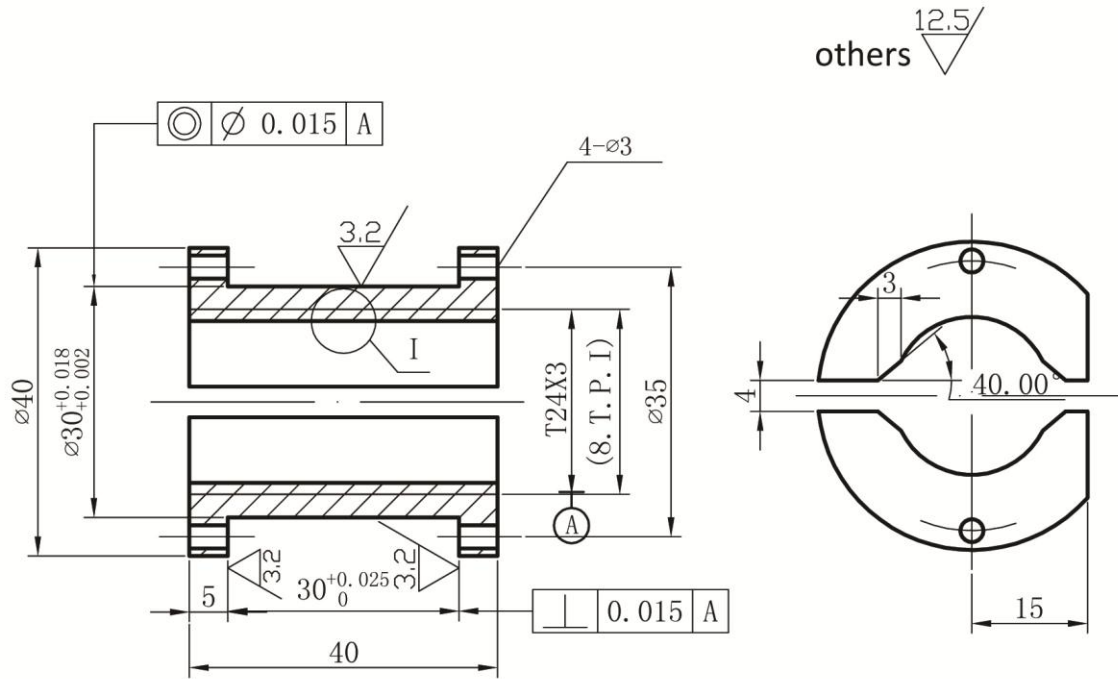

Fig14 Trouble shooting part--horizontal feeding nut



I (4 : 1)

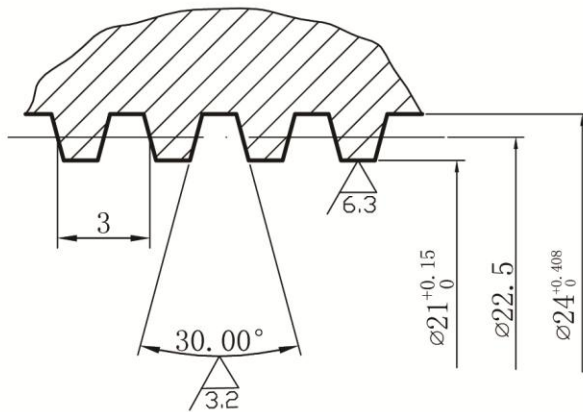

Fig15 Trouble shooting part--half nut

**Be Subject to alteration without notice**

**2012 EDITION**