

## Nema 34 Stepper Motor

Nema 34 hybrid bipolar stepper motor is a permanent magnet stepper motor with an end face size of 86mm x 86mm. Nema 34 stepper motor with high torque is used for CNC machine, 3D printer and robot arm, etc. It is simple structure, small size and easy assembly. ATO high torque stepper motor at low cost, including 2 phase open loop, 3 phase open loop and 2 phase closed loop, can be controlled by AC or DC digital stepper controllers for precise position control.

### 2 Phase Open Loop Stepper Motor



### Specification

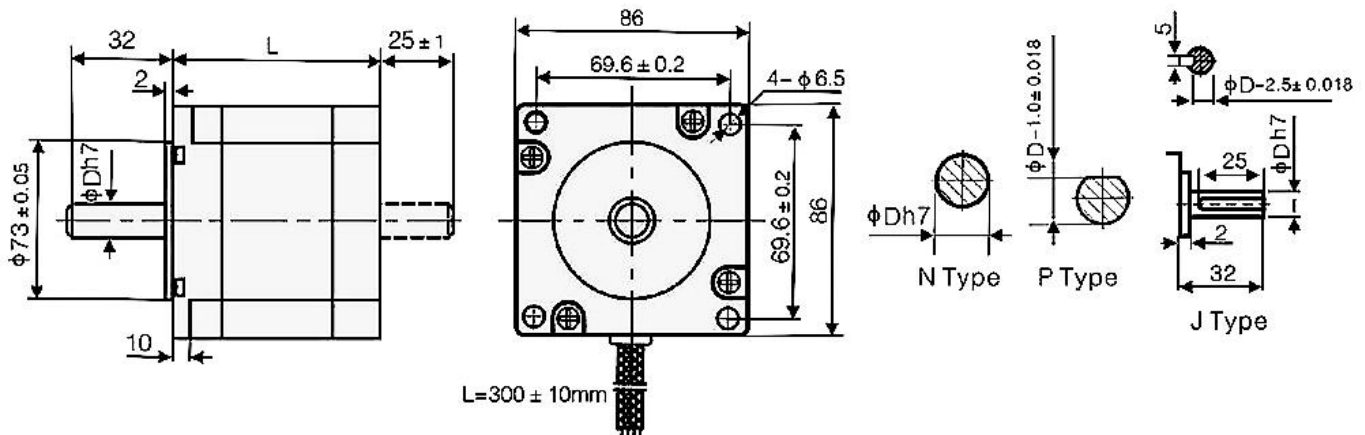

Model	Step Angle (°)	Motor Length (mm)	Rated Current (A)	Holding Torque (N.m)	Phase Resistance (Ω)	Phase Inductance (mH)	Rotor Inertia (g.cm <sup>2</sup> )	Lead Wires (NO.)	Motor Weight (Kg)
FY86ES350A	1.8	80	3.5	4.50	1.0	4.4	1500	4	2.00
FY86EM400A		94	4.0	6.00	0.8	3.5	2700	4	2.80
FY86EL400A		118	4.0	8.50	0.97	5.5	4100	4	3.80
FY86EC500A		150	5.0	12.0	1.20	6.0	6200	4	5.20

Technical Specification	
Shaft Diameter	14mm/ 12.7mm
Step Angle Accuracy	±5% (Full Step, No Load)
Resistance Accuracy	±10% (20°C)
Inductance Accuracy	±20% (1KHz)
Temperature Rise	80°C Max. (rated current, 2 phase on)
Ambient Temperature	-20°C~+50°C
Insulation Resistance	100MΩ Min. 500VDC
Dielectric Strength	1Min. 500VAC
Shaft Radial Play	0.02Max. 450g Load
Shaft Axial Play	0.08Max. 450g Load
Radial Max. Load	75N
Axial Max. Load	15N
Warranty Period	12 months
Certificate	CE, ROHs, FCC

## Wiring Diagram

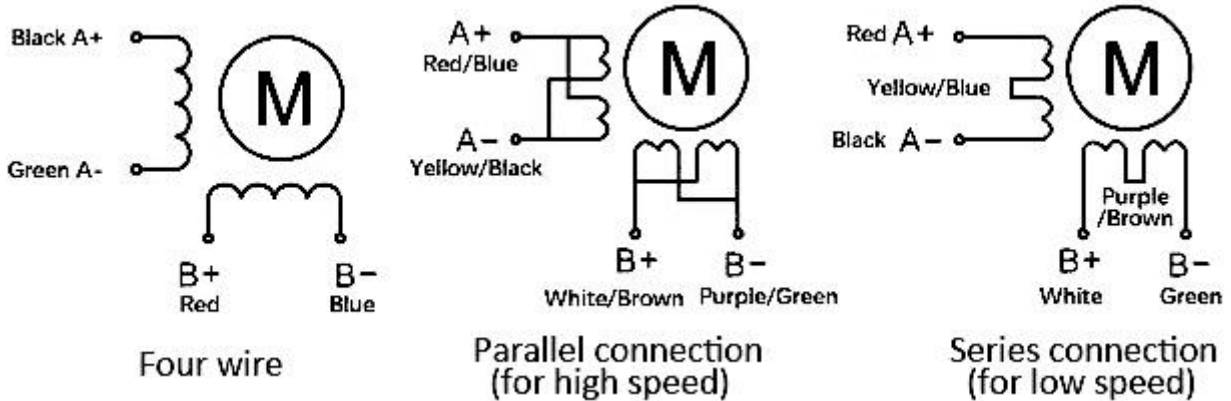

## Speed-Torque Curve Diagram

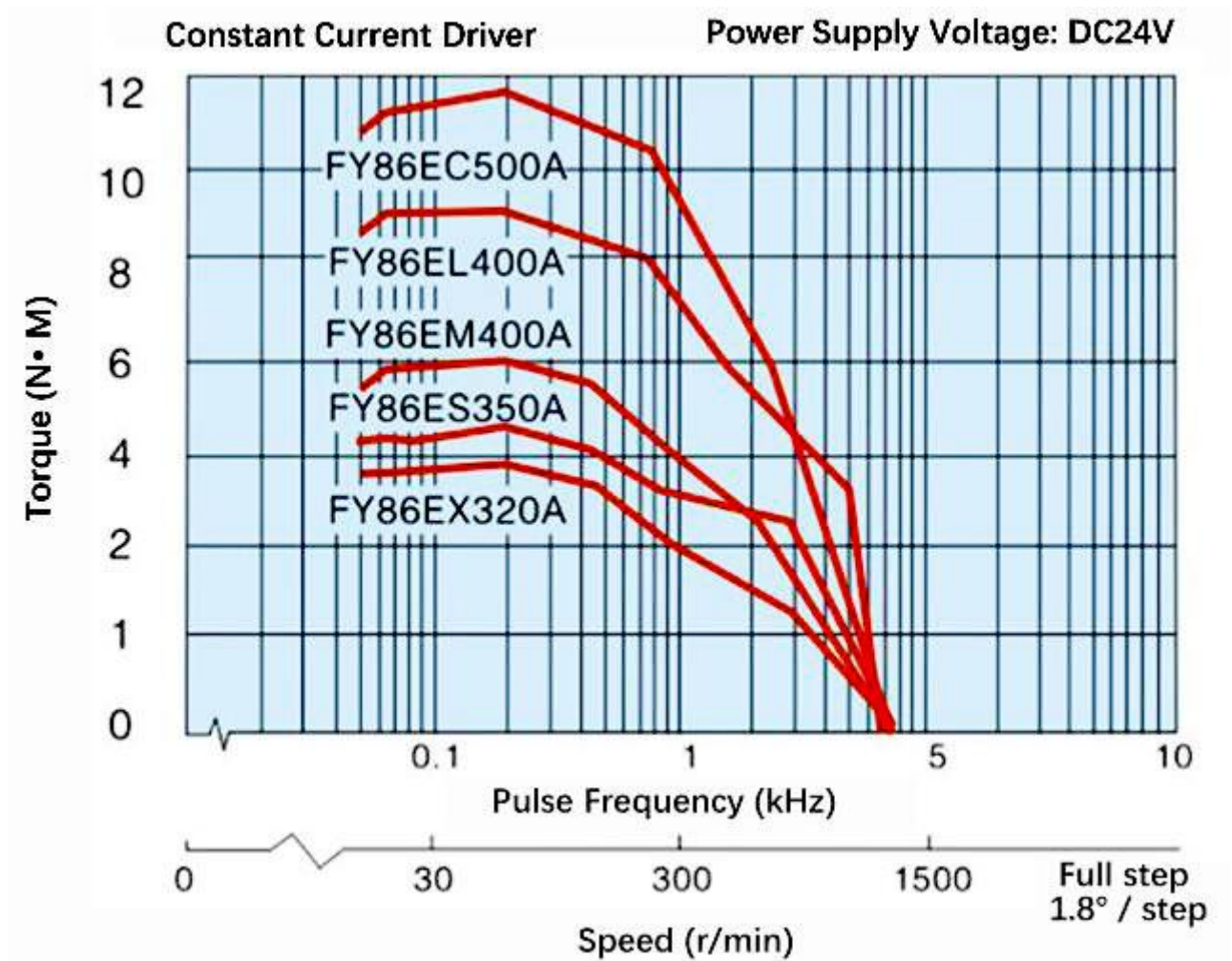

## 3 Phase Open Loop Stepper Motor



### Specification

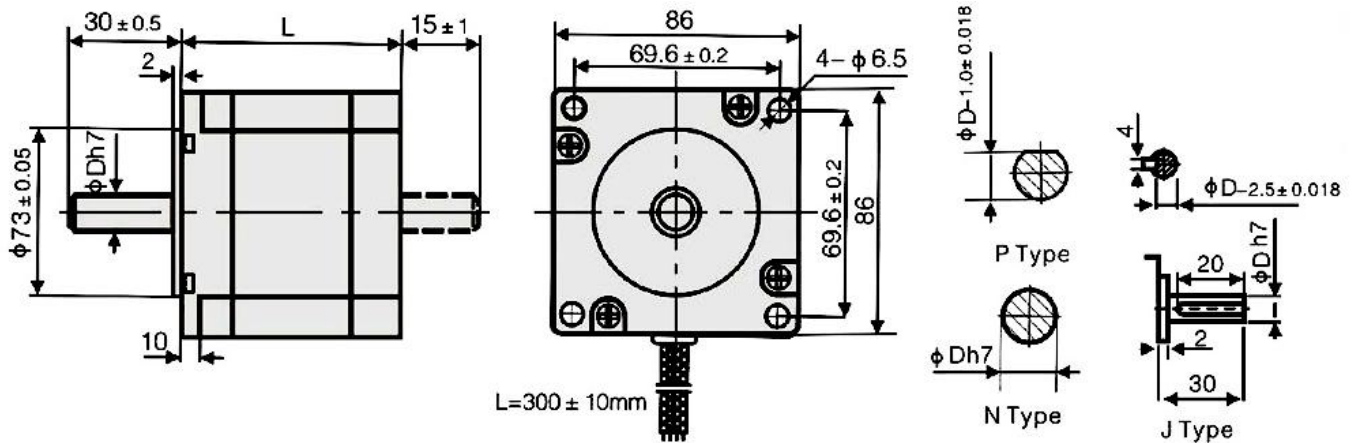

Model	Step Angle (°)	Motor Length (mm)	Rated Current (A)	Holding Torque (N.m)	Phase Resistance (Ω)	Phase Inductance (mH)	Rotor Inertia (g.cm <sup>2</sup> )	Lead Wires (NO.)	Motor Weight (Kg)
FY86TM200A	1.8	97	2.0	4.00	4.65	14.6	2400	3	2.80
FY86TC320A		145	3.2	8.50	2.60	9.57	4560	3	4.70
FY86TL300A		125	3.0	6.00	2.00	8.00	3480	3	3.80

Technical Specification	
Shaft Diameter	14mm
Step Angle Accuracy	±5% (Full Step, No Load)
Resistance Accuracy	±10% (20°C)
Inductance Accuracy	±20% (1KHz)
Temperature Rise	80°C Max. (rated current, 2 phase on)
Ambient Temperature	-20°C~+50°C
Insulation Resistance	100MΩ Min. 500VDC
Dielectric Strength	1Min. 500VAC
Shaft Radial Play	0.02Max. 450g Load
Shaft Axial Play	0.08Max. 450g Load
Radial Max. Load	75N
Axial Max. Load	15N
Warranty Period	12 months
Certificate	CE, ROHs, FCC

## Wiring Diagram

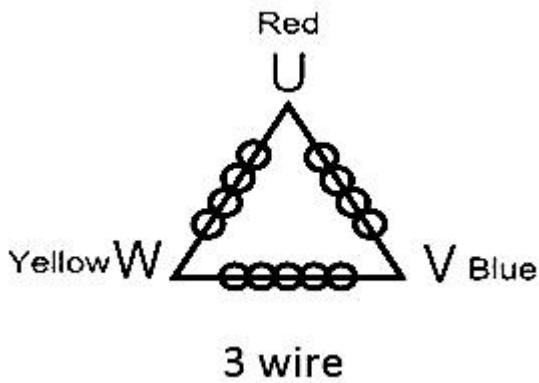

## Speed-Torque Curve Diagram

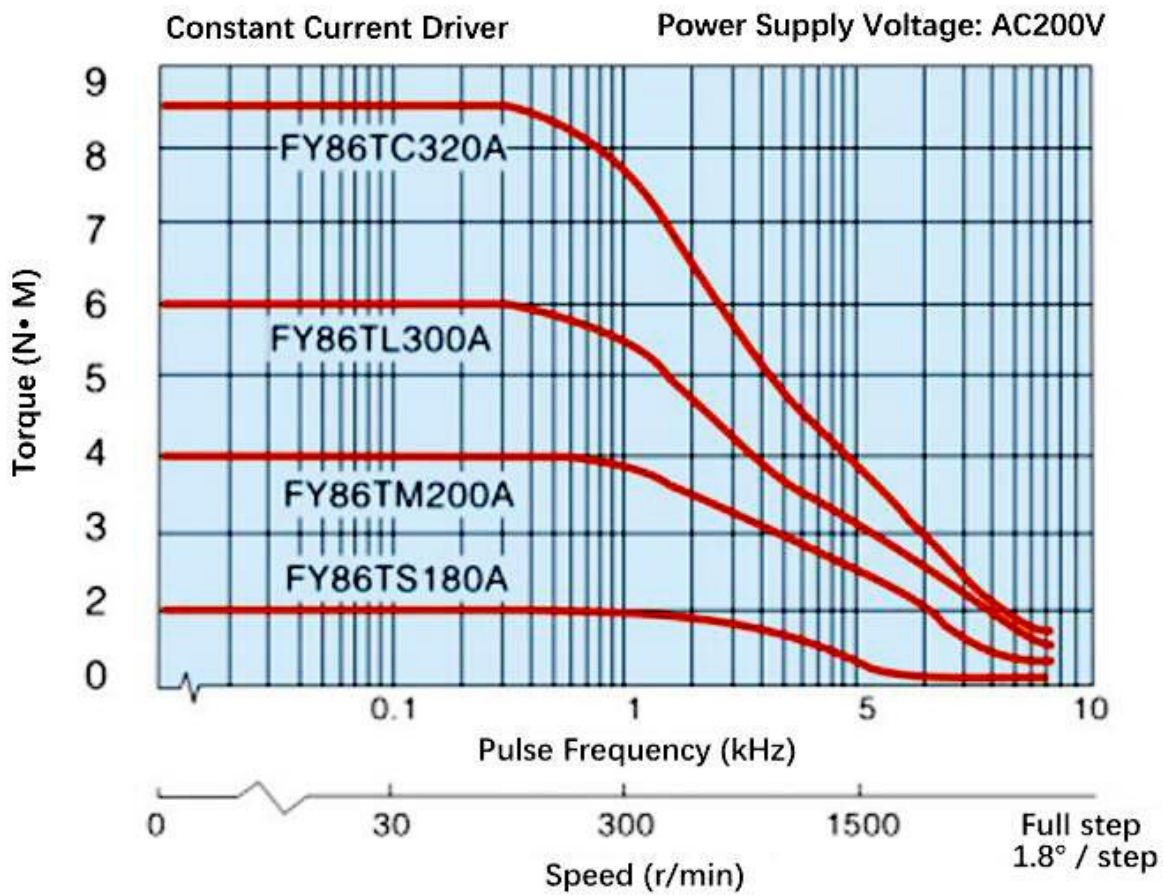

## 2 Phase Closed Loop Stepper Motor



### Specification

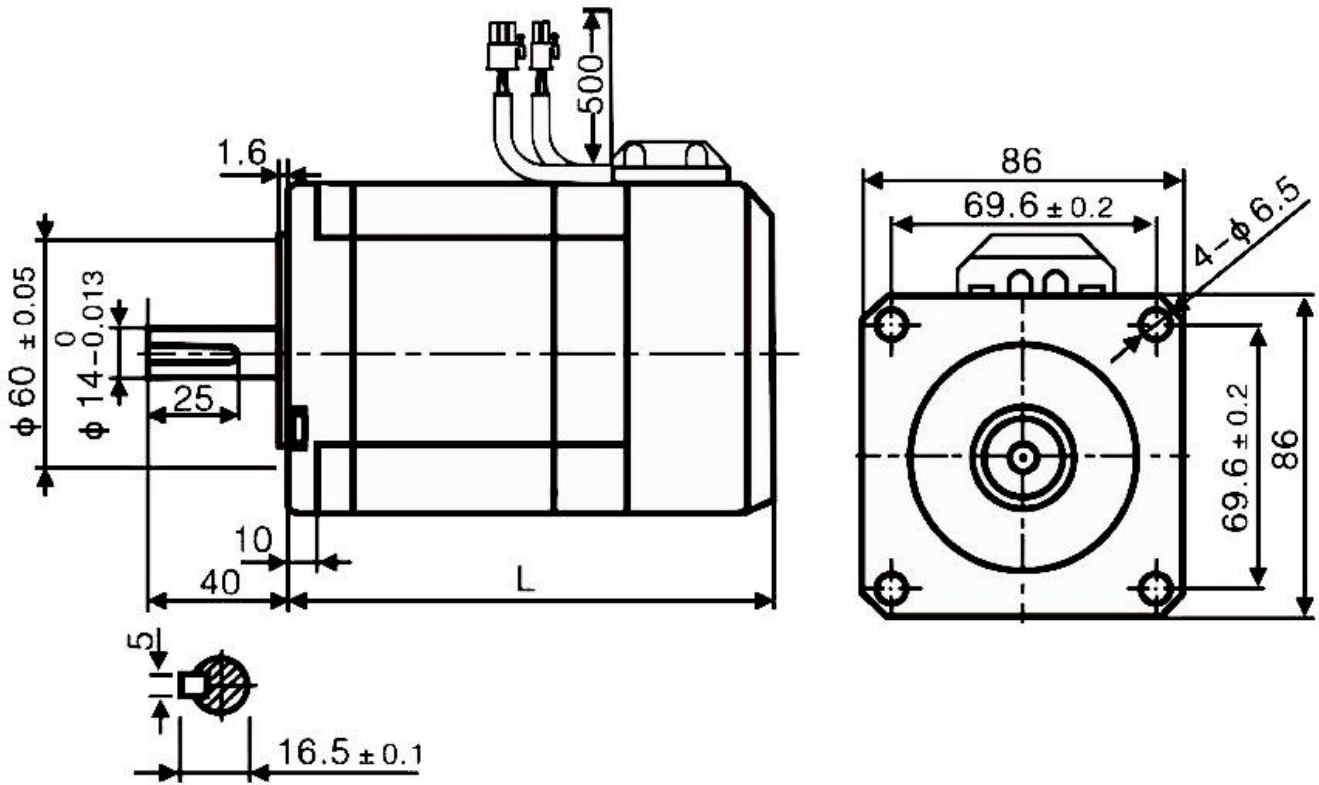

Model	Step Angle (°)	Motor Length (mm)	Rated Current (A)	Holding Torque (N.m)	Phase Resistance (Ω)	Phase Inductance (mH)	Rotor Inertia (g.cm <sup>2</sup> )	Lead Wires (NO.)	Motor Weight (Kg)
FY86EC620BC1	1.8	172	6.2	12.00	0.65	5.6	5600	4	5.00
FY86EM620BC1		102	6.2	4.50	0.34	2.5	1800	4	2.10
FY86EL620BC1		134	6.2	8.20	0.45	4.7	3600	4	3.60

Technical Specification	
Shaft Diameter	12mm
Step Angle Accuracy	±5% (Full Step, No Load)
Resistance Accuracy	± 10% (20°C)
Inductance Accuracy	±20% (1KHz)
Temperature Rise	80°C Max. (rated current, 2 phase on)
Ambient Temperature	-20°C~+50°C
Insulation Resistance	100MΩ Min. 500VDC
Dielectric Strength	1Min. 500VAC
Shaft Radial Play	0.02Max. 450g Load
Shaft Axial Play	0.08Max. 450g Load
Radial Max. Load	220N
Axial Max. Load	60N
Warranty Period	12 months
Certificate	CE, ROHs, FCC

### Motor & Encoder Wiring Diagram

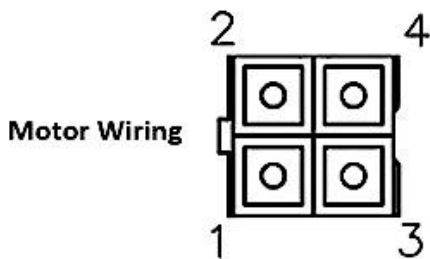

Motor End	Color	Function
1	Blue	B-
2	Red	B+
3	Green	A-
4	Black	A+

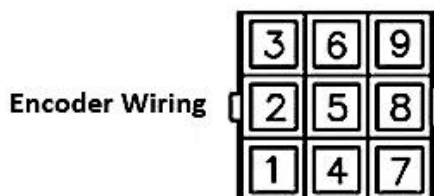

Encoder	Color	Function
1	Blue	EA+
2	—	—
3	Blue/White	EA+
4	Orange	EB+
5	—	—
6	Orange/White	EB-
7	Red	VCC
8	Black	GND
Encoder	Shield	



## Speed-Torque Curve Diagram

